

KÄRCHER

makes a difference

WD 3 Deluxe

Operating Instructions

Before first use of the unit
read these operating instructions
and act in accordance with them.

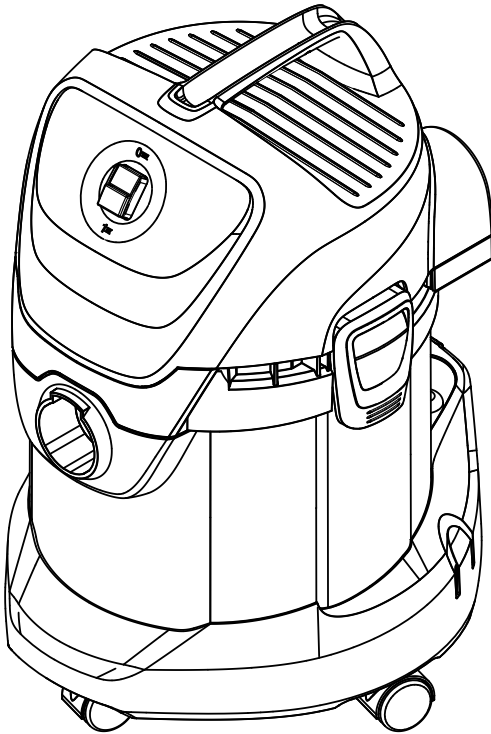

59689790 (05/19)

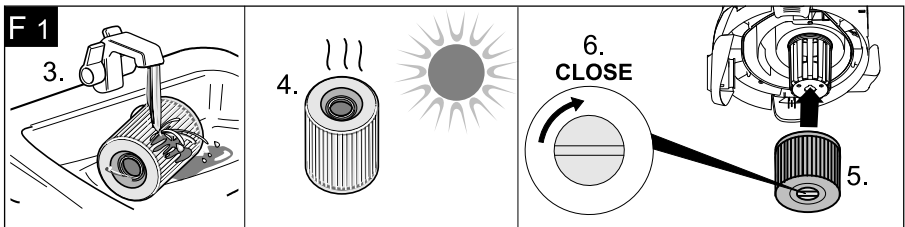
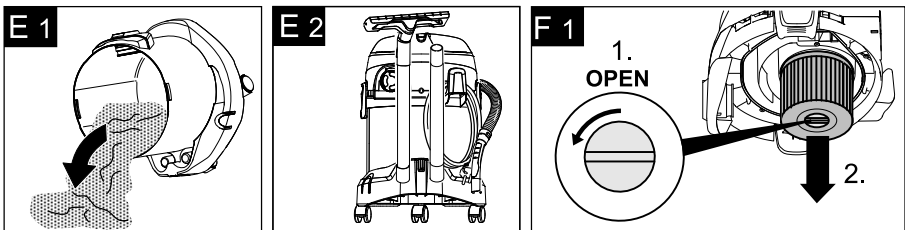
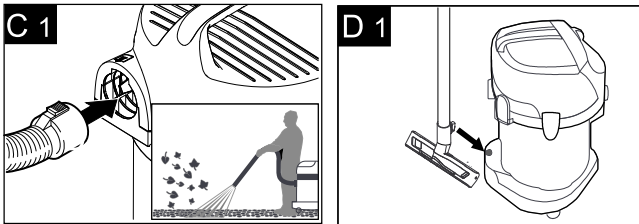
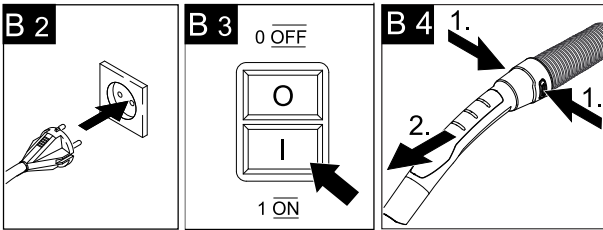
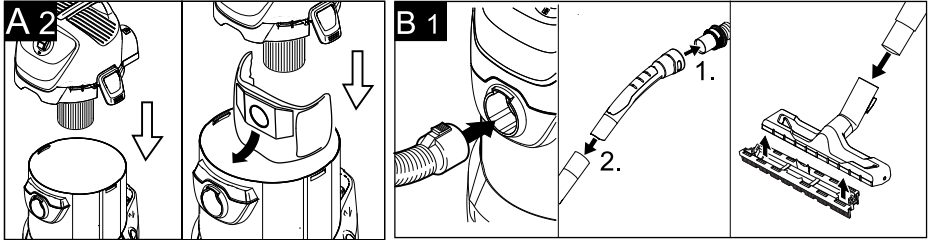
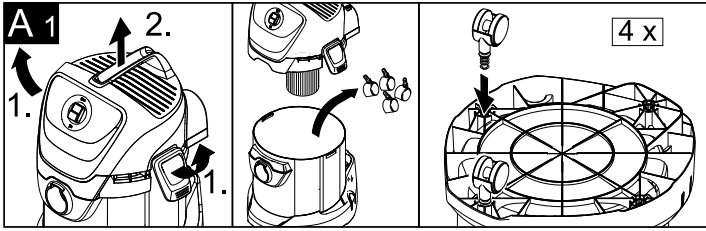

Contents

Contents	EN	3
General notes	EN	3
Safety instructions	EN	4
Description of the Appliance	EN	6
Operation	EN	8
Care and maintenance	EN	9
Troubleshooting	EN	9
Technical specifications	EN	9

Dear Customer,



Please read and comply with these original instructions prior to the initial operation of your appliance and store them for later use or subsequent owners.

General notes

Proper use

In accordance with the descriptions and the safety information in these operating instructions the appliance is intended for use as a multi-purpose vacuum cleaner.

This appliance has been designed for use in private households and is not intended for commercial use.

- Protect the unit from rain. Do not store outside.
- This device may not be used to suck in ash and soot.

Use the multi-purpose vacuum cleaner only with:

- Original filter bag.
- Original spare parts, accessories and special accessories.

The manufacturer is not responsible for any damages that may occur on account of improper use or wrong operations.

Environmental protection



The packaging material can be recycled. Please do not place the packaging into the ordinary refuse for disposal, but arrange for the proper recycling.



Old appliances contain valuable materials that can be recycled. Please arrange for the proper recycling of old appliances. Please dispose your old appliances using appropriate collection systems.

Disposing the filters and filter bags

Filters and filter bags are made from environment-friendly materials.

They can therefore be disposed off through the normal household garbage provided you have not sucked in substances that are not permitted to be thrown into household garbage.

Notes about the ingredients (REACH)

You will find current information about the ingredients at:

www.kaercher.com/REACH

Warranty

The terms of the guarantee applicable in each country have been published by our respective national distributors. We will repair possible faults on your unit free of charge within the warranty period, insofar as the faults are caused by material defects or defective workmanship. Guarantee claims should be addressed to your dealer or the nearest authorized customer service centre, and supported by documentary evidence of purchase.

Scope of delivery

The scope of delivery of your appliance is illustrated on the packaging. Check the contents of the appliance for completeness when unpacking.

In the event of missing accessories or any transport damage, please contact your dealer.

Customer Service

Our KÄRCHER branch will be pleased to help you further in the case of questions or faults.

Accessories and Spare Parts

Only use original accessories and spare parts, they ensure the safe and trouble-free operation of the device. For information about accessories and spare parts, please visit www.kaercher.com.

Safety instructions

⚠ DANGER

- *The appliance may only be connected to alternating current. The voltage must correspond with the type plate on the appliance.*
- *Never touch the mains plug and the socket with wet hands.*
- *Do not pull the plug from the socket by pulling on the connecting cable.*
- *Check the power cord with mains plug for damage before every use. To avoid risks, arrange immediately the exchange by an authorized customer service or a skilled electrician, if the power cord is damaged.*
- *To avoid accidents due to electrical faults we recommend the use of sockets with a line-side current-limiting circuit breaker (max. 30 mA nominal tripping current).*
- *Turn off the appliance and remove the mains plug prior to any care and maintenance work.*
- *Repair works may only be performed by the authorised customer service.*

⚠ WARNING

- *This appliance is not intended for use by persons with limited physical, sensory or mental capacities or lacking experience and/or skills, unless such persons are accompa-*

nied and supervised by a person in charge of their safety or they have received precise instructions on the use of this appliance and have understood the resulting risks.

- *Children may only use this appliance if they are over the age of 8 and supervised by a person in charge of their safety, or if they have received instructions on the use of this appliance and have understood the resulting risks.*
- *Children must not play with this appliance.*
- *Supervise children to prevent them from playing with the appliance.*
- *Cleaning and user maintenance must not be performed by children without supervision.*
- *Keep packaging film away from children - risk of suffocation!*
- *Switch the appliance off after every use and prior to every cleaning/maintenance procedure.*
- *Risk of fire. Do not vacuum up any burning or glowing objects.*
- *The appliance may not be used in areas where a risk of explosion is present.*
- *Immediately switch the appliance off or pull the power plug if foam forms or liquids escape!*

- *Do not use abrasives, glass or universal cleaners! Never immerse the appliance in water.*

Certain materials may produce explosive vapours or mixtures when agitated by the suction air! Never vacuum up the following materials:

- *Explosive or combustible gases, liquids and dust particles (reactive dust particles)*
- *Reactive metal dust particles (such as aluminium, magnesium, zinc) in combination with highly alkaline or acidic detergents*
- *Undiluted, strong acids and alkalies*
- *Organic solvents (such as petrol, paint thinners, acetone, heating oil).*

In addition, these substances may cause the appliance materials to corrode.

Hazard levels

⚠ DANGER

Pointer to immediate danger, which leads to severe injuries or death.

⚠ WARNING

Pointer to a possibly dangerous situation, which can lead to severe injuries or death.

⚠ CAUTION

Pointer to a possibly dangerous situation, which can lead to minor injuries.

ATTENTION

Pointer to a possibly dangerous situation, which can lead to property damage.

Description of the Appliance

When unpacking the product, make sure that no accessories are missing and that none of the package contents have been damaged. If you detect any transport damages please contact your dealer.

1 Suction hose connection

Illustration **B 1**

→ To connect the suction hose during vacuuming.

2 ON/OFF switch for appliance

Illustration **B 3**

→ **Position I:** Suction or blowing
Position 0: Appliance is switched off

3 Carrying handle

→ To carry the appliance or to remove the appliance head after unlocking.

4 Cable hook

Illustration **E 2**

→ To store the mains cable.

5 Blowing connection

Illustration **C 1**

→ Connect the suction hose to the blower connection, this will activate the blower function.

6 Container closure

Illustration **A 1**

→ Pull out to open, push in to lock.

7 Parking position

Illustration **D 1**

→ To rest the floor nozzle during work interruptions.

8 Accessory mount

Illustration **E 2**

→ The accessories compartment allows the storage of suction pipes and suction nozzles on the appliance.

9 Steering roller

Illustration **A 1**

→ The steering rollers are located in the waste container when the appliance is delivered. These must be attached prior to starting up the appliance.

10 Filter bag

Note: Do not use a filter bag for wet vacuuming!

Illustration **A 2**

→ **Recommendation:** To vacuum fine dust, use the filter bag.

11 Cartridge filter

Illustration **F 1**

→ The cartridge filter must always be installed - with wet and dry vacuuming.

Note: Let the wet cartridge filter dry prior to using it for dry vacuuming.

12 Suction hose with connecting piece

Illustration **B 1**

→ Push the suction hose into the connection on the appliance, it snaps in place.

→ In order to disconnect it, push down with your thumb and pull the suction hose out.

Note: Accessories, such as suction brushes (optional) can be directly attached to the connecting piece and thus connected to the suction hose. For convenient working even in tight spaces.

The removable handle can be attached between the accessories and the suction hose if necessary. See position 13.

Recommendation: In order to vacuum the floor, attach the handle to the suction hose.

13 Removable handle

Illustration **B 1**

→ Connect the handle with the suction hose until it snaps in place.

Illustration **B 4**

→ To remove the handle from the suction hose, press the notch using your thumb and pull off the handle.

Note: Due to removing the handle, accessories can be directly attached to the suction hose.

Recommendation: In order to vacuum the floor, attach the handle to the suction hose. See position 12.

14 Suction tubes 2 x 0.5 m

Illustration **B 1**

→ Put both suction tubes together and connect them with the handle.

15 Crevice nozzle

→ For edges, joints, heaters and hard to reach locations.

16 Floor nozzle

Illustration **B 1**

→ **Note:** For vacuuming dry dirt or water off the floor - always work with the insert (brush strip and rubber lip) in the floor nozzle.

17 Upholstery nozzle

→ For cleaning upholstered furniture, mattresses, laced curtains, etc.

18 Suction brush with soft bristles, black

→ For gentle cleaning of sensitive surfaces such as car dashboard or center console.

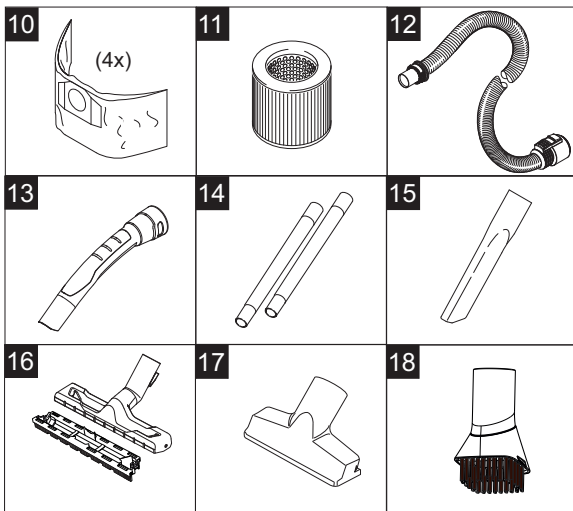
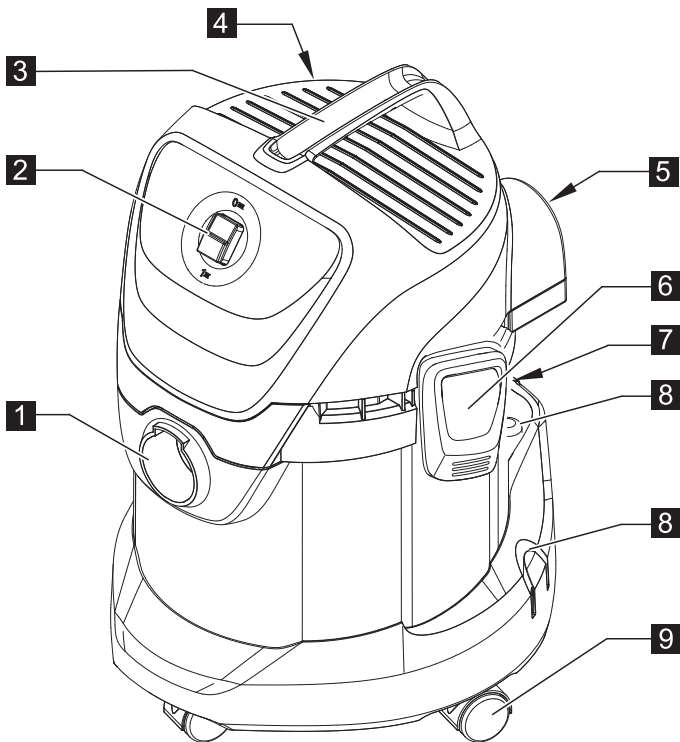

Operation

⚠ CAUTION

Always work with an inserted cartridge filter during wet as well as dry vacuum cleaning!

Before Startup

Illustration A 1

- Mount loose parts delivered with appliance prior to start-up.

Start up

Illustration B 1

- Connect accessories.

Illustration B 2

- Plug in the mains plug.

Illustration B 3

- Turn on the machine.

Dry vacuum cleaning

⚠ CAUTION

Check the filter for damage prior to installation and replace as necessary.

Work with a dry cartridge filter only!

Illustration A 2

- **Recommendation:** To vacuum fine dust, use the filter bag.

Information filter bag

- The filling level of the filter bag depends on the dirt that is sucked in.
- The filter bag needs to be replaced more frequently while sucking in fine dust, sand, etc.
- Clogged filter bags can burst - therefore make sure to replace the filter bag in a timely manner!

⚠ CAUTION

Vacuum cold ashes only when using a pre-filter.

Order no. basic design: 2.863-139.0, premium design: 2.863-161.0.

Wet vacuum cleaning

- For vacuuming up moisture or liquids pay attention to the correct floor nozzle insert and connect the corresponding accessories.

⚠ WARNING

Immediately switch the appliance off or pull the power plug if foam forms or liquids escape!

Do not use a filter bag!

Note: If the container is full, a float closes the suction opening, and the appliance works at a higher speed. Switch off the appliance immediately, and empty the container.

Blowing function

Cleaning hard to reach locations or, where vacuuming is not possible, like leaves from a gravel bed.

Illustration C 1

- Connect the suction hose to the blower connection, this will activate the blower function.

Interrupting operation

- Turn off the appliance.

Illustration D 1

- Hook the floor nozzle into the parking position.

Finish operation

- Turn off the appliance and disconnect the mains plug.

Empty the container

Illustration E 1

- Remove the appliance head and empty the reservoir.

Storing the appliance

Illustration E 2

- Stow away the mains cable and accessory at the machine. Store the appliance in a dry room.

Care and maintenance

⚠ DANGER

Turn off the appliance and remove the mains plug prior to any care and maintenance work.

Repair works may only be performed by the authorised customer service.

- Clean the appliance and accessory parts made of plastic with a commercial plastic cleaner.
- If required, rinse the container and accessories with water properly and dry them before reuse.

Illustration **F 1**

- Only clean the cartridge filter under running water; do not wipe or brush. Let it dry completely prior to installation.

Troubleshooting

Decreasing cleaning power

If the cleaning power of the appliance deteriorates please check the following:

- Accessories, suction hose or suction pipes are clogged, please remove the obstruction using a stick.

Illustration **A 2**

- Filter bag is full, install new filter bag.

Illustration **F 1**

- Cartridge filter is dirty, knock off dirt from cartridge filter and clean under running water if necessary.
- Replace damaged cartridge filter.

Technical specifications

Voltage 1~50-60 Hz	220-240	V
Output P _{nom}	1000	W
Mains fuse (slow-blow)	10	A
Container capacity	17	l
Water intake with handle	10	l
Water intake with floor nozzle	8	l
Power cord	H05VV-F 2x0,75	
Sound pressure level (EN 60704-2-1)	75	dB(A)
Weight (without accessories)	5,5	kg

Subject to technical modifications!



www.kaercher.com/dealersearch

Alfred Kärcher SE & Co. KG
Alfred-Kärcher-Str. 28-40
71364 Winnenden (Germany)
Tel.: +49 7195 14-0
Fax: +49 7195 14-2212

